

TB2150
15.8-TONNE



**POWERFUL
EXCAVATOR**

EXCAVATING EXCELLENCE

TAKEUCHI[®]
From World First to World Leader

The **TB2150** excavator

15.8-tonne with offset boom.

The TB2150 is the largest excavator in the Takeuchi line-up, meeting the growing demand from contractors and plant hirers for the popular Takeuchi brand in a larger 15.8-tonne weight class.

With a track footprint of 2690 x 3580mm the TB2150 offers power performance achieved in a compact machine size. Productivity is enhanced with a unique offset boom for maximum versatility on-site.

The TB2150 combines all the proven characteristics of Takeuchi excavators: smooth hydraulics, power performance, proven durability, high resale value, with maximum operator comfort and serviceability.

MAXIMUM FUEL EFFICIENCY

Power performance combined with maximum breakout force all compliant with low emission zone regulations.

Complete with a 85kW Deutz turbo engine;
Stage V • Low Emission • Low Noise.

Fuel Saving Features:

- Automatic idle
- Economy work-mode
- Electronic engine monitoring
- Electric dial throttle control
- Two-speed tracking with auto step down
- TFM - Remote utilisation data



POWERFUL BREAKOUT FORCE & OFFSET FLEXIBILITY

The TB2150 features massive breakout force essential for 15-tonne excavating, 96.3kN bucket breakout force and 85 kW of power.

The long reach at ground level to 8320mm and digging depth to 5225mm provide excellent operating parameters.

With a unique offset boom not available on conventional machines of this size the TB2150 is truly a unique machine.



SWITCH ACTIVATED BLADE FLOAT

To maximise ground finishing on-site the switch activated blade float is fitted as standard.

A heavy-duty dozer blade with a cylinder protection guard.

Exposed ground level hydraulic hoses are spiral steel wrapped for added protection.

The **OFFSET BOOM** configuration provides maximum versatility on-site when working in tight spaces. No more constant track repositioning, simply use the offset boom both left and right (77°/53°).





SAFETY

With an overall compact design and rounded corners, the TB2150 minimises potential machine damage. Hydraulic hoses are well positioned for safe attachment use.

Dual boom cylinders provide added lifting power and additional clearance for bucket and attachments. Boom and arm holding valves are factory fitted for added safety in the event of a hose burst failure.

The TB2150 offers excellent lifting capability. An audible warning lift alarm is standard for craning.



TSS - TAKEUCHI SECURITY SYSTEM

The TB2150 comes with **TSS immobiliser key** as standard. Includes 1 red master key and 3 black user keys. Can programme up to 13 user keys.



TFM - TAKEUCHI FLEET MANAGEMENT

TFM is a remote **TELEMATICS** system, using real time data to better manage your fleet and lower overall operating costs. Free of charge in warranty period.



EASY OPERATION & CONTROLS

Accumulator assisted pilot controls combined with cushioned boom, arm and swing cylinders, help reduce shock and vibrations for a smoother machine operation.

Boom and arm holding valves are factory fitted for added safety in the event of a hose burst failure

Engine accelerator control is conveniently located on the right hand armrest. Automatic two speed travel shifts into high torque mode when turning, pushing or travelling over inclines. The offset boom swing is operated by a foot pedal.

The TB2150 comes factory fitted with steel hydraulic hitch pipework and with safe hand/foot activation switches.



COMPATIBLE BREAKER

The TB2150 is compatible with a Takeuchi TKB802-S sound suppressed hydraulic breaker. Designed to meet the requirement for quieter operating environments.

ENHANCED FEATURES

With climate control and a large heated adjustable air suspension seat, operator's enjoy maximum all day comfort in a TB2150.

Dual flow hydraulic lines operated by sliders on both levers, for smooth control of variable flow and detent to accommodate a wide range of attachments, with optional password secure presets.

Rear-view and side-view cameras along with 5 all-round and blind-spot mirrors provide maximum 360 all-round visibility.

5 x high-visibility LED workzone lighting, cab, boom and side cover along with rear LED site visibility lighting all improve job site safety. The large rear counterweight lights provide added safety along with a motion alarm fitted as standard.

The TB2150 comes factory fitted with steel hydraulic hitch pipework and with safe hand/foot activation switches.



STANDARD FEATURES

(see website for the complete features list)

OPERATOR STATION

- All steel Cab (ROPS/ TOPS/ OPG)
- Adjustable armrest and deluxe highback heated air suspension seat.
- Wide-angle colour rear-view and side camera with auto-reverse activation
- Radio with stereo speakers MW/FM/ USB/ Bluetooth
- Cab mirror - 5 blind-spot mirrors
- Roof guard and steel rain-guard
- Large fully supporting foot travel pedals

ELECTRICAL

- 3x In-cab power sockets 12V/24V/USB
- Exterior - 24V power socket
- Switched roof beacon power socket - 12V
- 5 x hi-visibility LED workzone lighting - cab, boom and side cover
- Rear LED site visibility lighting

ENGINE

- DOC+DPF +SCR exhaust after treatment
- Dual fuel filtration - water trap
- Dual element air filter
- Service interval - 500 hours
- Working modes: Standard/ Eco/ Altitude



HYDRAULICS

- Cushioned boom, arm and swing cylinders
- Boom and arm holding check valves
- Lift overload alarm
- Aux flows - touchscreen adjustable
- Multi-attachment presets - password secure
- 1-way/2-way flow selector
- Aux with independent isolation valves
- Proportional auxiliary controls with detent
- AdBlue tank with audible refill level alarm
- Aux ports: 1st + 2nd standard, 3rd (pre-piped for hydraulic hitch), 4th optional

UNDERCARRIAGE AND FRAME

- Steel Tracks Standard - 700mm
- Dozer with switch activated blade float
- Twin heavy-duty dozer cylinders
- Triple flanged track rollers
- Lower carriage and blade tie down points



RELIABLE TRACK DESIGN

The TB2150 comes with triple flanged rollers that support the track in multiple positions improving machine stability. The upper roller maintains track alignment and helps shed debris.

High torque auto step-down travel motors deliver on-demand tracking power when dozing, turning and climbing.



TB2150 COMPACT EXCAVATOR



MAXIMUM ALL DAY COMFORT WITH A HIGH VISIBILITY CAB

Multi-adjustable heated high-back air suspension seat, with adjustable arm rests for long days of productive operation with minimal operator fatigue.

Spacious comfortable cab with excellent storage and foot room. Large fully supporting foot travel pedals, foot rests and foot controlled offset boom.

The digital climate control with air-con provides a comfortable operating environments.

Isolated mounted ROPS/TOPS/FOPS cab minimises noise levels and vibration, with a new noise reduction system.

The operators station gives good all-round visibility, with wide-angle colour rear and side view cameras including auto-reverse activation and split screen display.



SERVICEABILITY

Full width steel engine hood provides maximum service access.

The fuel system automatically bleeds air from fuel lines on a fuel-depleted machine saving on time, tools and unnecessary service calls.

Auto-stop refuelling pump makes it easier for operators, with room for grease gun storage for daily maintenance.

Hydraulic test ports are located at the front offside for ease of hydraulic system diagnostic testing.

The handrail and anti-slip steps provide easy access to upper service area to access the coolant expansion tank.



TB2150 POWERFUL EXCAVATOR

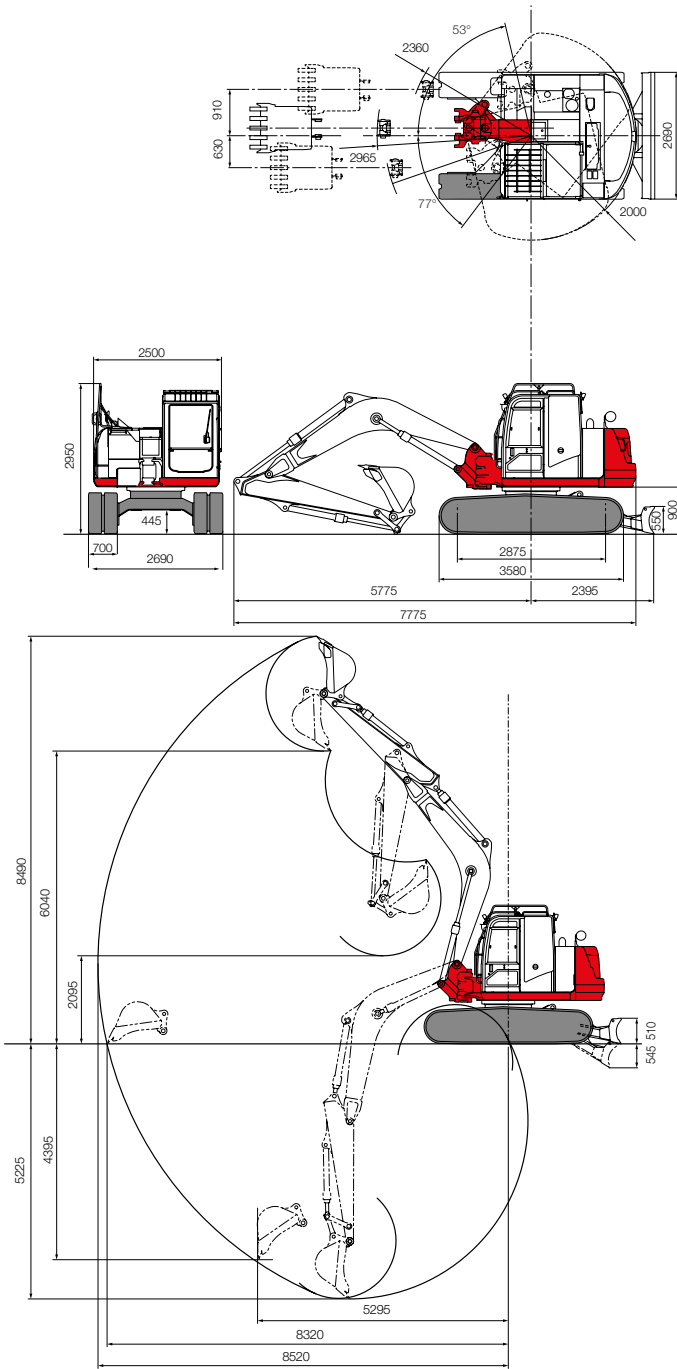

TB2150 Standard UK Specification Middle Arm - Steel Track (Rubber Track option)

Engine	
Make	DEUTZ
Model	TCD3.6L4
Rated Output (kW)	85 / 2000
Maximum Torque (Nm)	460
Cylinders	4
Displacement (cc)	3621
Electrical System	24 volt
Dimensions & Weight	
Operating weight (bucket, hitch, fuel) kg	15860
Length (Transporting) (mm)	7775
Width (mm)	2690
Height (mm)	2950
Ground Clearance (mm)	445
Min Radius/Max Front Offset (mm)	2965/2360
Slew Radius (mm)	2000
Dozer Blade (W x H) (mm)	2690 x 550
Operating Information	
Max Digging Depth (mm)	5225
Max Dump Height (mm)	6040
Max Reach at Ground Level (mm)	8320
Max Vertical Dig Depth (mm)	4395
Max Bucket Digging Force (kN)	96.3
Max Arm Digging Force (kN)	59.8
Hydraulic System	
Main System Pressure (bar)	340
Pump Type	Variable Displacement
1st Auxiliary Maximum Flow (l/min) / Pressure (bar)	224 / 270
*2nd Auxiliary Maximum Flow (l/min) / Pressure (bar)	55 / 230
Swing System	
Boom Swing Angle (L/R)	77°/53°
Slew Speed (rpm)	10.8
Slew Motor	Piston
Slew Brake	Disc
Undercarriage	
Traction Motor	Variable Displacement
Traction Drive	Epicyclic Gearing
Traction Brake	Disc
Track Width (mm)	700
Ground Contact Length (mm)	2875
Ground Pressure (kpa)	47.7
Travel Speed (k/ph)	3.1 / 5.5
Maximum Gradeability	35°
Capacities	
Hydraulic System (l)	234
Fuel Tank (l)	278
Engine Lubrication (l)	10
Cooling System (l)	27
DEF Tank (l)	20
Health and Safety	
Noise Level Sound Power Level (LwA)	98 dB
Vibration Hand Arm / Body m/sec ²	≤2.5 / ≤0.5

**2 YEAR
2,000 HOUR**

WARRANTY

Takeuchi machines come with a 2 year/2000 hour warranty as standard. Before fitment of a hydraulic attachment, machine auxiliary pressure and flow should be accurately measured. For all lifting specifications please refer to the lift charts on the Takeuchi website or operator manual. In accordance with our established policy of constant improvement, we reserve the right to amend these specifications at any time without notice. Photographs shown may feature non-standard equipment.

For more information locally contact:



SCAN ME

To find your local dealer

Takeuchi Mfg (UK) Ltd, Unit E2B Kingsway Business Park, John Boyd Dunlop Drive, Rochdale, Lancashire OL16 4NG
info@takeuchi-mfg.co.uk www.takeuchi-mfg.co.uk

@TakeuchiUK

TAKEUCHI
From World First to World Leader