

TB2150R
15.7-TONNE



**POWERFUL
EXCAVATOR**

EXCAVATING EXCELLENCE

TAKEUCHI[®]
From World First to World Leader

TB2150R excavator powerful 15.7-tonne with fixed boom and short tail

The TB2150R is the largest excavator in the Takeuchi line-up. It features a fixed conventional boom and reduced tail swing providing 15.7-tonnes of powerful excavating performance.

The TB2150R combines all the proven characteristics of Takeuchi excavators: smooth hydraulics, power performance, proven durability, high resale value, with maximum operator comfort and serviceability.

MAXIMUM POWER & EFFICIENCY

The massive added power and breakout force of the TB2150R delivers maximum productivity. Powered by a Deutz 85 kW engine, the TB2150R meets all the very latest emission standards for environmentally friendly working sites. (EU Stage IV / EPA Tier 4 Emission Compliant). This engine also utilises a DOC + SCR exhaust after treatment system.

Takeuchi excavators are built with proven smooth hydraulic controls and the TB2150R is no exception, with familiar precision touch-controls that make the Takeuchi an operator's favourite.

CONVENTIONAL FIXED BOOM

The fixed boom position, to the right of the cab, is compact enough for maximum visibility. The boom and arm holding check valves are positioned to minimize any potential site damage.



The hydraulic hoses are efficiently routed to the adjacent valve chest, conveniently located at the front offside of the cab for easy access.



COMPATIBLE BREAKER

The TB2150R is compatible with a Takeuchi TKB802-S sound suppressed hydraulic breaker. Designed to meet the requirement for quieter operating environments.



MAXIMUM FUEL EFFICIENCY

Fuel Saving Features:

- Automatic idle
- Economy work-mode
- Electronic engine monitoring
- Electric dial throttle control
- Two-speed tracking with auto step down
- TFM - Remote utilisation data



STAGE V 
COMPLIANT

NEW NOISE 
REDUCTION



TSS - TAKEUCHI SECURITY SYSTEM

The TB2150R comes with **TSS** immobiliser key as standard. Includes 1 red master key and 3 black user keys. Can programme up to 13 user keys.



TFM - TAKEUCHI FLEET MANAGEMENT

TFM is a remote **TELEMATICS** system, using real time data to better manage your fleet and lower overall operating costs. Free of charge in warranty period.

ENHANCED FEATURES

Boom and arm holding check valves are factory fitted for added safety in the event of a hose burst failure. An audible warning lift alarm is standard for craning.

The TB2150R comes factory fitted with steel hydraulic hitch pipework and with safe hand/foot activation switches.

Dual flow hydraulic lines operated by sliders on both levers, for smooth control of variable flow and detent to accommodate a wide range of attachments, with optional password secure presets.

With AC climate control and a large heated adjustable air suspension seat, operator's enjoy maximum all day comfort.

LED work lights provide excellent illumination in low light conditions - located on the boom, cab, front and rear as standard. The large rear counterweight lights provide added safety along with a travel alarm fitted as standard.

Rear-view and side-view cameras along with 5 blind-spot mirrors provide maximum 360 all-round visibility.



SWITCH ACTIVATED BLADE FLOAT

To maximise ground finishing on-site the switch activated blade float is fitted as standard.

A heavy-duty dozer blade with twin cylinder protection guards. Exposed ground level hydraulic hoses are spiral steel wrapped for added protection.

REDUCED SHORT TAIL

With a minimum overhang of just 350mm on 700mm steels the TB2150R is a very compact 15-tonne excavator. It gets to work in the most confined spaces.



RELIABLE TRACK DESIGN

The TB2150R comes with triple flanged rollers that support the track in multiple positions improving machine stability. The upper roller maintains track alignment and helps shed debris.

High torque auto step-down travel motors deliver on-demand tracking power when dozing, turning and climbing.

STANDARD FEATURES

(see website for the complete features list)

OPERATOR STATION

- All steel Cab (ROPS/ TOPS/ OPG)
- Adjustable armrest and deluxe highback heated air suspension seat.
- Cab mirror - 5 blind-spot mirrors
- Wide-angle colour rear-view and side camera with auto-reverse activation
- Radio with stereo speakers MW/FM/ USB/ Bluetooth
- AC/ climate control/ heater/ de-mister
- Gas lift-assist window slides into recess
- Roof guard and steel rain guard
- Large fully supported foot travel pedals

ELECTRICAL

- Sockets 12V/USB in-cab & 12V cab-front
- Switched roof beacon power socket - 12V
- 5x forward and 1x back LED workzone lights
- Emergency engine shut-down switch
- Electric refuelling pump - extra length

ENGINE

- DOC+DPF+SCR exhaust after treatment
- Dual fuel filtration - water trap
- Dual element air filter
- Service interval - 500 hours
- Working modes: Standard/ Eco/ Altitude



HYDRAULICS

- Cushioned boom, arm and swing cylinders
- Boom and arm holding check valves
- Lift overload alarm
- Dual boom cylinder protection guards
- Aux flows - touchscreen adjustable
- Multi-attachment presets - password secure
- 1-way/2-way flow selector switch
- Aux with independent isolation valves
- Proportional auxiliary controls with detent
- Aux ports: 1st + 2nd standard, 3rd (pre-piped for hydraulic hitch), 4th optional

UNDERCARRIAGE AND FRAME

- Steel Tracks Standard - 700mm
- Dozer with switch activated blade float
- Triple flanged track rollers
- Tie down anchor points



TB2150R POWERFUL EXCAVATOR



MAXIMUM ALL DAY COMFORT WITH A HIGH VISIBILITY CAB

The large comfortable air-conditioned cab offers excellent storage and lots of foot room with fully supporting foot travel pedals, footrests and foot-controlled offset. The multi-adjustable heated high-back air suspension seat comes with adjustable arm rests.

The operators station gives good all-round visibility, with wide-angle colour rear and side view cameras with auto-reverse activation displays split screen.

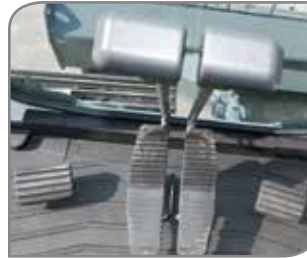

SERVICEABILITY

The TB2150R is designed for easy servicing and daily routines.

- Well-positioned enhanced visual display unit - warning indicators, rpm, hour meter, fuel, battery charge, temperature, oil pressure and maintenance alerts.
- Filter access points, centralised grease points and a convenient counterweight access to the oil filter and dipstick.
- Front right access panel provides access to the hydraulic valve chest.
- Right rear panel allows access to the fuel and pilot line filters and hydraulic pumps.
- The left side cover provides excellent access to the DEF tank, dual element air cleaner, batteries and grease gun storage.
- A dedicated compartment for the electric refuelling pump with auto-shut off alongside AdBlue warning and filler points.
- Exhaust after-treatment system – includes a maintenance free diesel oxidation catalyst (DOC), and a selective catalytic reduction (SCR) with diesel exhaust fluid (DEF) to comply with latest Stage V emissions requirements.
- The grip-steps and handlebars provide safe access to service areas at the top of the machine.



TB2150R POWERFUL EXCAVATOR



Mono Boom: Long-Arm

All measurements are in mm.
Long-Arm / (2-piece boom)

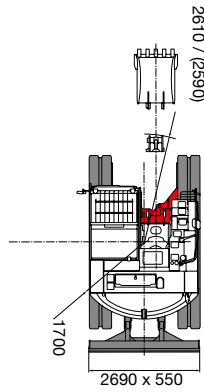
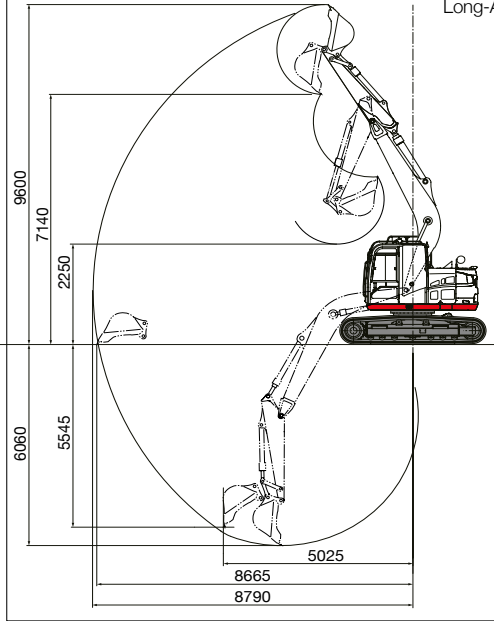

2-piece Boom

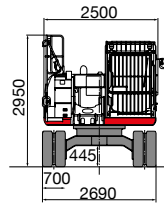
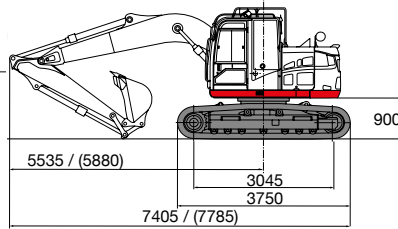
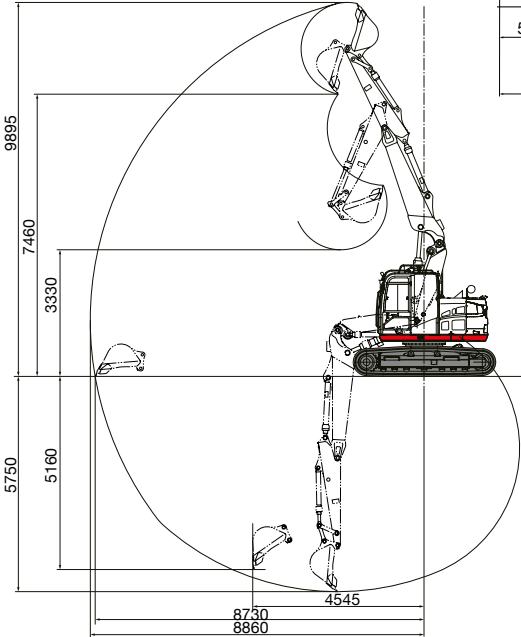

TB2150R

Standard UK Spec – Steel Tracks Long-Arm Mono Boom
Option: - (2-piece Boom)

| Engine | |
|---|-----------------------|
| Make | DEUTZ |
| Model | TCD3.6L4 |
| Rated Output (kW) | 85 / 2000 |
| Maximum Torque (Nm) | 460 |
| Cylinders | 4 |
| Displacement (cc) | 3621 |
| Electrical System | 24 volt |
| Dimensions & Weight | |
| Op. Weight kg (bucket, hitch, fuel) Long-Arm / (2-piece) | 15710 (16270) |
| Length (Transporting) (mm) Long-Arm / (2-piece) | 7405 (7785) |
| Width (mm) | 2690 |
| Height (Transporting) (mm) | 3190 / 2950 |
| Ground Clearance (mm) | 445 |
| Dozer Blade (W x H) (mm) | 2690 x 550 |
| Operating Information | |
| Max Digging Depth (mm) | 6060 (5750) |
| Max Dump Height (mm) | 7140 (7460) |
| Max Reach at Ground Level (mm) | 8665 (8730) |
| Max Vertical Dig Depth (mm) | 5545 (5160) |
| Max Bucket Digging Force (kN) | 96.3 |
| Max Arm Digging Force (kN) | 60.0 |
| Hydraulic System | |
| Main System Pressure (bar) | 340 |
| Pump Type | Variable Displacement |
| 1st Auxiliary Maximum Flow (l/min) / Pressure (bar) | 224 / 270 |
| *2nd Auxiliary Maximum Flow (l/min) / Pressure (bar) | 55 / 230 |
| Swing System | |
| Slew Radius (mm) | 1700 |
| Slew Speed (rpm) | 11 |
| Slew Motor | Piston |
| Slew Brake | Disc |
| Undercarriage | |
| Traction Motor | Variable Displacement |
| Traction Drive | Epicyclic Gearing |
| Traction Brake | Disc |
| Track Width (mm) | 700 |
| Ground Contact Length (mm) | 3045 |
| Ground Pressure (kpa) | 46.2 / (48.1) |
| Travel Speed (k/ph) (steel) | 2.7 / 5.1 |
| Maximum Gradeability | 35° |
| Capacities | |
| Hydraulic System (l) | 235 |
| Fuel Tank (l) | 221 |
| Engine Lubrication (l) | 10 |
| Cooling System (l) | 27 |
| DEF Tank (l) | 20 |
| Health & Safety | |
| Noise / Sound Power Level (LwA) | 99 dB |
| Vibration Hand Arm / Body m/sec ² | ≤2.5 / ≤0.5 |

**2 YEAR
2,000 HOUR**

WARRANTY

Takeuchi machines come with a 2 year/2000 hour warranty as standard.

Before fitment of a hydraulic attachment, machine auxiliary pressure and flow should be accurately measured. For all lifting specifications please refer to the lift charts on the Takeuchi website or operator manual.

In accordance with our established policy of constant improvement, we reserve the right to amend these specifications at any time without notice. Photographs shown may feature non-standard equipment.

4/2024

For more information locally contact:



SCAN ME

To find your
local dealer

Takeuchi Mfg (UK) Ltd, Unit E2B Kingsway Business Park,
John Boyd Dunlop Drive, Rochdale, Lancashire OL16 4NG
info@takeuchi-mfg.co.uk www.takeuchi-mfg.co.uk

@TakeuchiUK

TAKEUCHI
From World First to World Leader