

TB230
3-TONNE



**COMPACT
EXCAVATOR**

EXCAVATING EXCELLENCE

TAKEUCHI[®]
From World First to World Leader

TB230 powerful 3-tonne high performance excavator

The TB230 is a powerful yet compact machine for this popular 3-tonne weight class available as a cab or canopy.

With increased power this proven Takeuchi provides maximum efficiency on-site, featuring many key features as standard. The TB230 is built for plant hire, groundworks and earthmoving.

The TB230 combines all the proven characteristics of Takeuchi excavators: smooth hydraulics and power performance, proven durability and high resale value, maximum operator comfort and serviceability.

3-TONNE POWER PERFORMANCE

The TB230 offers maximum performance with excellent bucket breakout force of 20.9kN and arm digging force of 12.9kN all powered by a 18.2kW Yanmar 3 cylinder engine.

The TB230 has plenty of power and greater torque along with a well proven, high performance hydraulic Rexroth pump for greater oil flow for faster cycle times and increased efficiency.

The TB230 offers a compact 3-tonne excavator with a track footprint of just 1450 x 1900mm.



MAXIMUM FUEL EFFICIENCY

Fuel Saving Features:

- Engine auto stop
- Automatic idle
- Economy work-mode
- Electronic engine monitoring
- Electric dial throttle control



ENHANCED FEATURES

Boom and arm holding valves are factory fitted for added safety in the event of a hose burst failure. An audible warning lift alarm is standard for craning.

Dual flow hydraulic lines operated by a joystick slider, auxiliary flows are adjustable from the touchscreen control panel with preset modes to match all types of attachments with optional password secure presets.

COMPATIBLE BREAKER

The TB230 is compatible with a Takeuchi TKB102-S sound suppressed hydraulic breaker. Designed to meet the requirement for quieter operating environments.





SWITCH ACTIVATED BLADE FLOAT

To maximise ground finishing on-site the switch activated blade float is fitted as standard.

The heavy-duty dozer blade is fitted with a blade cylinder protection guard.

Exposed ground level hydraulic hoses are spiral steel wrapped for added protection.



OPERATOR COMFORT

The TB230 offers equivalent cab size of a larger size excavator – spacious and roomy with excellent all around visibility

The cab comes with a gas lift-assist front window, this slides into the recess above. The removable lower glass panel can be safely secured behind the seat.

The well-positioned colour VDU illuminates all the active operating switch functions.

Accumulator assisted pilot controls combined with cushioned boom and swing cylinders, help reduce shock and vibrations for a smoother machine operation.



STANDARD FEATURES

(see website for the complete features list)

OPERATOR STATION

- All steel Cab/Canopy (ROPS/ TOPS/ OPG)
- Adjustable deluxe highback seat with retracting seat belt, drinks holder and adjustable armrests
- In-cab radio with stereo speakers MW/FM/ USB/ Bluetooth
- Gas lift-assist window slides into recess
- Skylight with retractable sunshade
- Front screen rain guard
- Full foot travel pedals

ELECTRICAL

- Internal/ external power sockets - 12V
- Switched roof beacon power socket - 12V
- Travel alarm
- LED workzone lights
- Emergency engine shut-down switch
- Electrical refuelling pump

ENGINE

- Stage V Ready < 19kW - low emission
- Dual fuel filtration with water trap
- Dual element air filter
- Automatic Idle
- Service interval - 250 hours
- Working modes: Standard/ Eco/ Altitude



HYDRAULICS

- Cushioned boom and swing cylinders
- Boom and arm holding check valves
- Lift overload alarm
- Aux flows adjustable
- Multi-attachment presets - password secure
- 1-way/2-way flow selector
- Aux with independent isolation valves
- Proportional auxiliary controls with detent
- Aux ports: 1st + 3rd (pre-piped for hydraulic hitch) 2nd optional

UNDERCARRIAGE AND FRAME

- Dozer blade with switch activated blade float
- Triple flanged track rollers & sealed bearings

MAXIMUM SAFETY

All steel panels and counterweight along with boom and blade cylinder guards provide protection for key engine and hydraulic components.

LED workzone lighting ensures maximum visibility. Boom and arm check valves, lift overload and travel alarm are standard safety features.



ATTACHMENT VERSATILITY

Preset auxiliary flows adjustable from the operator console VDU with optional password secure presets.

PRE-PIPED FOR HITCH AS STANDARD

The TB230 has factory fitted steel hydraulic hitch pipework as standard, with safe hand/foot activation switches.



RELIABLE TRACK DESIGN

Triple flanged rollers support the track in multiple positions improving machine stability. The upper roller maintains track alignment and helps shed debris.

High torque auto step-down travel motors deliver on-demand tracking power when dozing, turning and climbing.



TB230 COMPACT EXCAVATOR



RELIABILITY & SERVICEABILITY

The TB230 has maximum accessibility for easy daily routine servicing with large wide opening covers.

- The rear engine access features clustered key service check points for easier daily checks and maintenance, with central filter positions for speedy servicing and less downtime.
- The off-side service hood provides access to the control valves, hydraulic lines and hydraulic tank.
- Electric refuelling pump with fast fill-up and auto shut off as standard. Convenient and secure remote gauge for assistance when refuelling with a lockable fuel fill.
- The TB230 offers easy track maintenance with grease filled service track adjusters and maintenance-free sealed bearing track rollers.
- The cab features a roof mounted switched beacon socket.
- The canopy is fitted with a prewired beacon switch.



TSS - TAKEUCHI SECURITY SYSTEM

The TB230 comes with TSS as standard. Includes 1 red master key and 3 black user keys. Can programme up to 13 user keys.



TB230 COMPACT EXCAVATOR

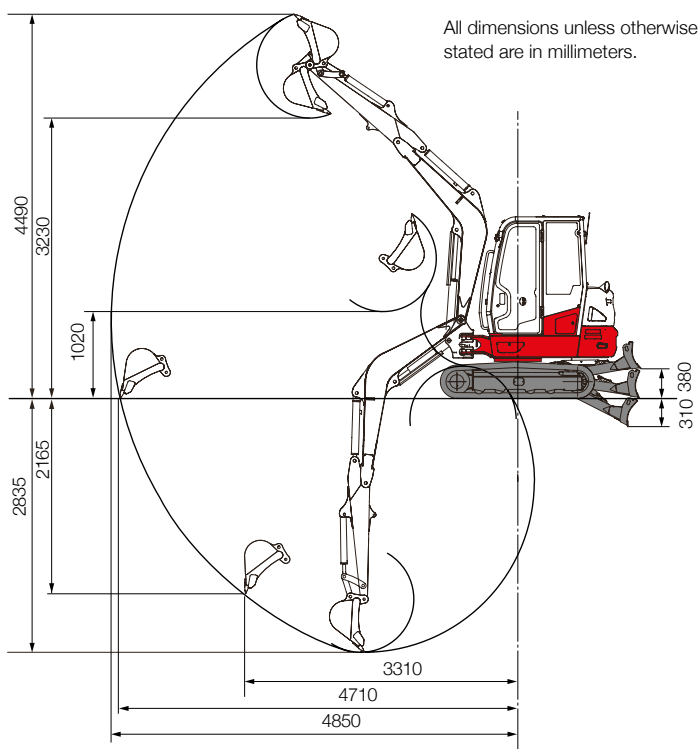
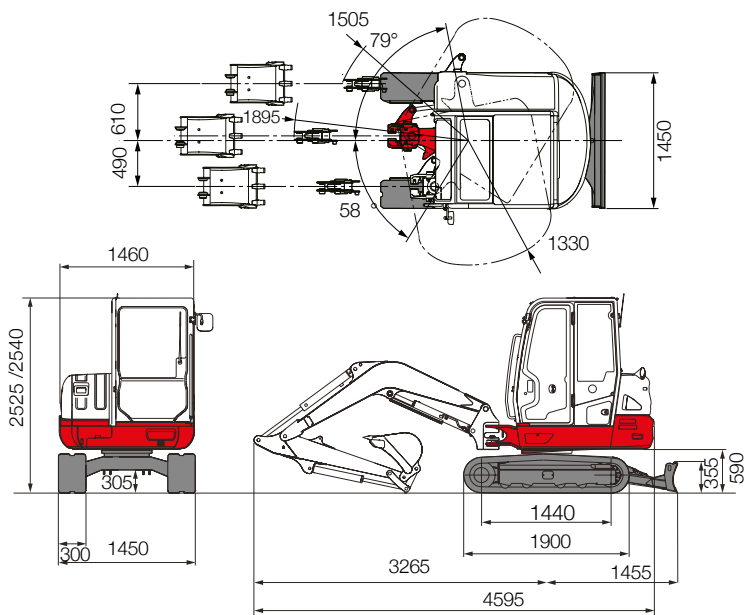

All dimensions unless otherwise stated are in millimeters.

TB230 Standard UK Specification Long Arm / Rubber Tracks

Engine	
Make	YANMAR
Model	3TNV88F
Rated Output (kW)/rpm	18.2 / 2400
Maximum Torque (Nm)	92.2
Cylinders	3
Displacement (cc)	1642
Electrical System	12v 64A

Dimensions & Weight	
Op. Weight (bucket, hitch, fuel) kg	3020 / 2920
Overall Length (mm) for transport	4595
Width (mm)	1450
Height Cab/Canopy (mm)	2525 / 2540
Ground Clearance (mm)	305
Min. Front Swing Radius (mm)	1505
Slew Radius (mm)	1330
Dozer Blade (W x H) (mm)	1450 x 355

Operating Information	
Max Digging Depth (mm)	2835
Max Dump Height (mm)	3230
Max Reach at Ground Level (mm)	4710
Max Vertical Digging Depth (mm)	2165
Max Bucket Digging Force (kN)	20.9
Max Arm Digging Force (kN)	12.9

Hydraulic System	
Set Pressure (bar)	210
Pump Type - Rexroth	Variable x 2 + Gear x 2
1st Aux Max Flow l/min	54
Pressure bar	210
2nd Aux Max Flow l/min	21
Pressure bar	200

Swing System	
Boom Swing Angle (L/R)	79° / 58°
Slew Speed (rpm)	10.3
Slew Motor	Constant Volume Piston Motor
Slew Brake	Wet Friction Plate

Undercarriage	
Traction Motor	Axial Piston
Traction Drive	Planetary
Traction Brake	Disc
Track Width (mm)	300
Ground Contact Length (mm)	1440
Ground Pressure (kpa)	29.3
Travel Speed (km/h)	2.9 / 5.2
Maximum Gradeability	30°

Capacities	
Hydraulic System (l)	56
Fuel Tank (l)	46
Engine Lubrication (l)	4.7
Cooling System (l)	4

Health & Safety	
Noise / Sound Power Level (LwA)	93 dB
Vibration Hand Arm / Body m/sec ²	≤2.5 / ≤0.5

**2 YEAR
2,000 HOUR**

WARRANTY

Takeuchi machines come with a 2 year/2000 hour warranty as standard.

Before fitment of a hydraulic attachment, machine auxiliary pressure and flow should be accurately measured. For all lifting specifications please refer to the lift charts on the Takeuchi website or operator manual.

In accordance with our established policy of constant improvement, we reserve the right to amend these specifications at any time without notice. Photographs shown may feature non-standard equipment.

For more information locally contact:



SCAN ME

To find your local dealer

Takeuchi Mfg (UK) Ltd, Unit E2B Kingsway Business Park,
John Boyd Dunlop Drive, Rochdale, Lancashire OL16 4NG
info@takeuchi-mfg.co.uk www.takeuchi-mfg.co.uk

@TakeuchiUK

TAKEUCHI
From World First to World Leader