

**TB240**  
**4-TONNE**



**POWERFUL  
COMPACT EXCAVATOR**

**EXCAVATING EXCELLENCE**

**TAKEUCHI**<sup>®</sup>  
*From World First to World Leader*

# TB240 Powerful compact excavating

The TB240 combines all the proven characteristics of Takeuchi excavators: smooth hydraulics, power performance, proven durability, high resale value, with maximum operator comfort and serviceability.

With excellent power and greater torque the TB240 delivers outstanding performance. The well proven, high performance hydraulic system delivers greater oil flow for faster cycle times, increased efficiency and smooth excavating performance.

## MAXIMUM OPERATING PERFORMANCE

The TB240 offers exceptional operating performance on site for a 4-tonne weight category with dig depth of 3465mm and ground reach of 5425mm.

The TB240 is full of key features as standard including accumulator assisted pilot controls combined with cushioned boom, arm and swing cylinders to help reduce shock and vibrations for a smoother machine operation.

Boom and arm holding valves minimise cylinder drift and help maintain load control in the event of a hose failure. The lift alarm can be turned off when not needed but provides an audible warning when the boom is reaching hydraulic lifting capacity.

The auxiliary detent switch prevents operator fatigue when continuously operating attachments.

Dual proportional control comes as standard.



### COMPATIBLE BREAKER

The TB240 is compatible with a Takeuchi TKB302-S sound suppressed hydraulic breaker.

Designed to meet the requirement for quieter operating environments.



## MAXIMUM FUEL EFFICIENCY

Fuel Saving Features:

- Automatic idle
- Economy work-mode
- Electronic engine monitoring
- Electric dial throttle control
- Two-speed tracking with auto step down
- TFM - Remote utilisation data



## 4-TONNE POWER PERFORMANCE

The TB240 delivers proven power performance in a compact overall size.

The TB240 offers maximum performance with excellent bucket breakout force of 30.8kN and 18.3kN arm digging force.

Powered by a 26.7kW Yanmar 4 cylinder engine with DPF, to meet Stage V emission regulations.

**STAGE V** ✓  
**READY**



### TSS - TAKEUCHI SECURITY SYSTEM

The TB240 comes with TSS immobiliser key standard. Includes 1 red master key and 3 black user keys. Can programme up to 13 user keys.



### TFM - TAKEUCHI FLEET MANAGEMENT

TFM is a remote **TELEMATICS** system, using real time data to better manage your fleet and lower overall operating costs. Free of charge in warranty period.





## ENHANCED FEATURES

The TB240 comes complete with air-con fitted as standard in the large comfortable cab.

The machine features LED workzone lighting for maximum efficiency, visibility and safety on site.

Convenient 1st auxiliary and quick hitch circuit are plumbed to the mid-arm. The dual flow hydraulic lines are operated by sliders on both levers, for smooth control of variable flow and detent to accommodate a range of attachments. Auxiliary flows adjustable from the operator console VDU with optional password secure presets.

The TB240 comes with factory fitted steel hydraulic hitch pipework as standard, with safe hand/foot activation switches.



## ROBUST SITE PROTECTION

Cast steel wraparound counterweight and all steel panels provide robust protection. Well-positioned hydraulic hoses minimise potential damage and are well protected.

Tough components and heavy-duty design adds to durability. Travel alarm fitted as standard.



## SWITCH ACTIVATED BLADE FLOAT

To maximise ground finishing on-site the switch activated blade float is fitted as standard.

A heavy-duty dozer blade with a blade cylinder protection guard.

Exposed ground level hydraulic hoses are spiral steel wrapped for added protection.

## RELIABLE TRACK DESIGN

Triple flanged rollers support the track in multiple positions improving machine stability. The upper roller maintains track alignment and helps shed debris.

High torque auto step-down travel motors deliver on-demand tracking power when dozing, turning and climbing.



## STANDARD FEATURES

(see website for the complete features list)

### OPERATOR STATION

- All steel Cab (ROPS/ OPG)
- Adjustable deluxe highback seat with retracting seat belt, drinks holder and adjustable armrests
- Radio with stereo speakers MW/FM/ USB/ Bluetooth
- AC/ multi vent heater/ de-mister
- Gas lift-assist window slides into recess
- Skylight with retractable sunshade
- Front screen rain-guard
- Large fully supported foot travel pedals

### ELECTRICAL

- Internal/ external power sockets - 12V
- Switched roof beacon power socket - 12V
- LED workzone lights
- Travel alarm
- Emergency engine shut-down switch
- Electric refuelling pump

### ENGINE

- DOC+DPF exhaust after treatment
- Dual fuel filtration - water trap
- Dual element air filter
- Service interval - 500 hours
- Working modes: Standard/ Eco/ Altitude



### HYDRAULICS

- Cushioned boom, arm and swing cylinders
- Boom and arm holding check valves
- Lift overload alarm
- Aux flows - touchscreen adjustable
- Multi-attachment presets - password secure
- 1-way/2-way flow selector
- Aux with independent isolation valves
- Proportional auxiliary controls with detent
- Aux ports: 1st + 3rd (pre-piped for hydraulic hitch), 2nd optional

### • UNDERCARRIAGE AND FRAME

- Dozer with switch activated blade float
- Triple flanged track rollers
- Tie down anchor points



# TB240 POWERFUL COMPACT EXCAVATOR



## MAXIMUM ALL DAY COMFORT

The TB240 has been designed for comfortable all-day operating. The large operator cab features highback fully adjustable suspension seat, headrest and ergonomically positioned hand and foot controls, plenty of foot room, air-con and multi-vent heater.

The TB240 offers excellent all-round visibility with LED workzone lights as standard and a gas lift-assist retractable front window, with removable / stowable lower glass. Extra cab features include a large skylight with sun-shade and a rain guard for open window operating.

The well-positioned colour visual display unit illuminates active operating switch functions; lift overload, ECO and altitude modes, auto idle and auxiliary detent. Operators can easily select auxiliary preset modes to match all types of attachments with optional password secure presets.



## MAXIMUM SERVICEABILITY

The steel engine hood and off-side cover provide unparalleled access to engine and hydraulic components simplifying all aspects of machine maintenance - all accessible at ground level.

### REAR SERVICE DOOR

- For access to the daily check points: dipstick, engine oil fill and filter alongside the hydraulic pump pressure detection points, fuel water-trap and air filter.
- Clustered service points make for quick and easy regular service routines.

### OFF-SIDE

- Lockable service panel for access to the hydraulic tank, control valve, fuel filter, battery, radiator, hydraulic and fuel cooler.
- Fuel filler points with electric refuelling pump, fast fill-up and auto shut off as standard, stowed in a lockable compartment.



# TB240 POWERFUL COMPACT EXCAVATOR

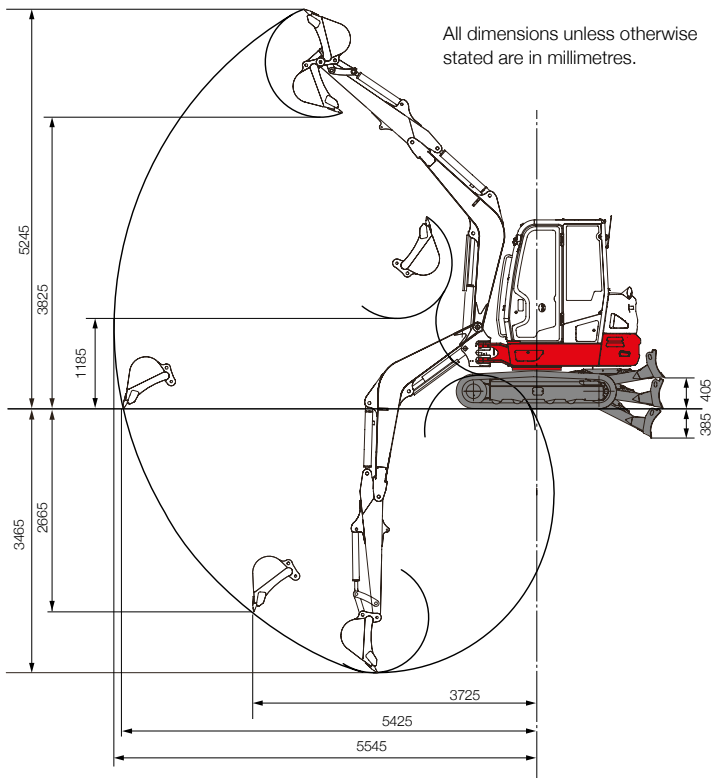
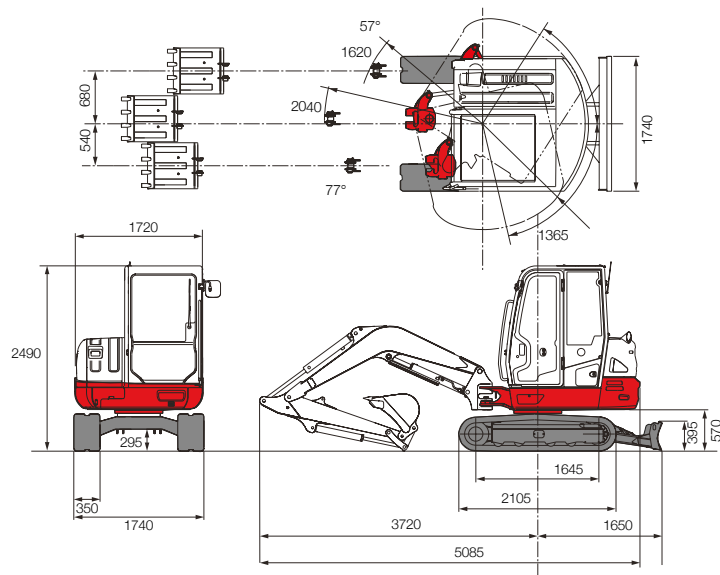

**2 YEAR  
2,000 HOUR**

**WARRANTY\***

Takeuchi machines come with a 2 year/2000 hours warranty as standard.

Before fitment of a hydraulic attachment, machine auxiliary pressure and flow should be accurately measured.

\*Lifting; the mass weight of slings / hitches / bucket to be deducted from the rated load to determine the net load that may be lifted.

## TB240

Standard UK Specification Cab - Long Arm / Rubber Tracks

Engine	
Make	YANMAR
Model	4TNV88C-CSTB DPF
Rated Output (kW)/rpm	26.7/2200
Maximum Torque (Nm)	144.9
Cylinders	4
Displacement (cc)	2189
Electrical System	12 v 90 amp
Dimensions & Weight	
Op. Weight (bucket, hitch, fuel) kg	4037
Overall Length (mm) for transport	5085
Width (mm)	1740
Height (mm)	2490
Ground Clearance (mm)	295
Min. Front Swing Radius (mm)	1620
Slew Radius (mm)	1365
Dozer Blade (W x H) (mm)	1740 x 395
Operating Information	
Max Digging Depth (mm)	3465
Max Dump Height (mm)	3825
Max Reach at Ground Level (mm)	5425
Max Reach at Vertical Digging Depth (mm)	3725
Max Bucket Digging Force (kN)	30.8
Max Arm Digging Force (kN)	18.3
Hydraulic System	
Set Pressure (bar)	240
Pump Type	Variable x 2 + Gear x 2
1st Aux Max Flow l/min	65
Pressure bar	206
2nd Aux Max Flow l/min	23
Pressure bar	206
Swing System	
Boom Swing Angle (L/R)	77°/57°
Slew Speed (rpm)	9.6
Slew Motor	Constant Volume Piston Motor
Slew Brake	Disc
Undercarriage	
Traction Motor	Variable Displacement
Traction Drive	Planetary Epicyclic Gear
Traction Brake	Wet Friction Plate
Track Width (mm)	350
Ground Contact Length (mm)	1645
Ground Pressure (kPa)	31.6
Travel Speed (km/h)	2.9/5.3
Maximum Gradeability	30°
Capacities	
Hydraulic System (l)	74
Fuel Tank (l)	70
Engine Lubrication (l)	7.4
Cooling System (l)	9
Health & Safety	
Noise / Sound Power Level (LwA)	96 dB
Vibration Hand Arm / Body m/sec <sup>2</sup>	≤2.5 / ≤0.5

For all lifting specifications please refer to lifts charts on the Takeuchi website or operator manual. In accordance with our established policy of constant improvement, we reserve the right to amend these specifications at any time without notice. Photographs shown may feature non-standard equipment.

4/2023

For more information locally contact:



SCAN ME

To find your local dealer

Takeuchi Mfg (UK) Ltd, Unit E2B Kingsway Business Park,  
John Boyd Dunlop Drive, Rochdale, Lancashire OL16 4NG  
info@takeuchi-mfg.co.uk www.takeuchi-mfg.co.uk

@TakeuchiUK

**TAKEUCHI**  
From World First to World Leader