

TB260
6-TONNE



**POWERFUL
COMPACT EXCAVATOR**

EXCAVATING EXCELLENCE

TAKEUCHI[®]
From World First to World Leader

TB260 powerful 6-tonne excavator in a compact size

The TB260 combines all the proven characteristics of Takeuchi excavators: smooth hydraulics, power performance, proven durability, high resale value, with maximum operator comfort and serviceability.

The TB260 has plenty of power and greater torque along with a well proven, high performance hydraulic system delivering greater oil flow for faster cycle times and increased efficiency.

MAXIMUM OPERATING PERFORMANCE

With a track footprint of just 2000 x 2575mm, the TB260 with its compact size gets maximum accessibility on restricted sites. With a massive ground reach of 6130mm and dig depth of 3895mm the TB260 offers maximum performance on site.

Accumulator assisted pilot controls combined with cushioned boom, arm and swing cylinders, help reduce shock and vibrations for a smoother machine operation.

Boom and arm holding valves minimise cylinder drift and help maintain load control in the event of a hose failure. The lift alarm can be turned off when not needed but provides an audible warning when the boom is reaching hydraulic lifting capacity.

The auxiliary detent switch prevents operator fatigue when using continuously operating attachments. Dual proportional control comes as standard.



COMPATIBLE BREAKER

The TB260 is compatible with a Takeuchi TKB302-S sound suppressed hydraulic breaker. Designed to meet the requirement for quieter operating environments.



POWER PERFORMANCE

Powered by a Yanmar engine with DPF, to meet Stage V emission regulations, The TB260 features 43.2 kN bucket breakout force and 25.6 kN digging arm force – high power for a 6-tonne excavator.

STAGE V ✓
COMPLIANT

MAXIMUM FUEL EFFICIENCY

Fuel Saving Features:

- Automatic idle
- Economy work-mode
- Electronic engine monitoring
- Electric dial throttle control
- Two-speed tracking with auto step down
- TFM - Remote utilisation data



TSS - TAKEUCHI SECURITY SYSTEM

The TB260 comes with TSS as standard. Includes 1 red master key and 3 black user keys. Can programme up to 13 user keys.



TFM - TAKEUCHI FLEET MANAGEMENT

TFM is a remote **TELEMATICS** system, using real time data to better manage your fleet and lower overall operating costs. Free of charge in warranty period.



BUILT FOR SITE

Cast steel wraparound counterweight and all steel panels provide robust protection. Well-positioned hydraulic hoses minimise potential damage and are well protected.

Tough components and heavy-duty design adds to durability.

Travel alarm fitted as standard.

The TB260 features LED workzone lighting for maximum efficiency, visibility and safety on site.

The TB260 comes with factory fitted steel hydraulic hitch pipework as standard, with safe hand/foot activation switches.

Convenient 1st / 2nd auxiliary and quick hitch circuit plumbed to the mid-arm. The dual flow hydraulic lines are operated by sliders on both levers, for smooth control of variable flow and detent to accommodate a range of attachments. Auxiliary flows are adjustable from the operator console VDU with optional password secure presets.



REDUCED TAIL SWING

The compact TB260 features a shorter than average tail swing compared to conventional 6-tonne excavators.

A 1300mm tail swing radius combined with maximum 300mm overhang at 90° to track, rounded corners and enhanced all around visibility, helps minimise potential machine damage in restricted areas.

RELIABLE TRACK DESIGN

Triple flanged rollers support the track in multiple positions improving machine stability. The upper roller maintains track alignment and helps shed debris.

High torque auto step-down travel motors deliver on-demand tracking power when dozing, turning and climbing.



SWITCH ACTIVATED BLADE FLOAT

To maximise ground finishing on-site the switch activated blade float is fitted as standard.

A heavy-duty dozer blade with a blade cylinder protection guard.

Exposed ground level hydraulic hoses are spiral steel wrapped for added protection.

STANDARD FEATURES

(see website for the complete features list)

OPERATOR STATION

- All steel Cab (ROPS/ OPG)
- Adjustable deluxe highback seat with retracting seat belt, drinks holder and adjustable armrests
- Radio with stereo speakers MW/FM/ USB/ Bluetooth
- AC/ multi vent heater/ de-mister
- Gas lift-assist window slides into recess
- Skylight with retractable sunshade
- Front screen rain guard
- Large fully supported foot travel pedals

ELECTRICAL

- Internal/ external power sockets - 12V
- Switched roof beacon power socket - 12V
- LED workzone lights
- Travel alarm
- Emergency engine shut-down switch
- Electric refuelling pump

ENGINE

- DOC+DPF exhaust after treatment
- Dual fuel filtration - water trap
- Dual element air filter
- Service interval - 500 hours
- Working modes: Standard/ Eco/ Altitude



HYDRAULICS

- Cushioned boom, arm and swing cylinders
- Boom and arm holding check valves
- Lift overload alarm
- Aux flows - touchscreen adjustable
- Multi-attachment presets - password secure
- 1-way/2-way flow selector
- Aux with independent isolation valves
- Proportional auxiliary controls with detent
- Aux ports: 1st + 2nd standard, 3rd (pre-piped for hydraulic hitch)

UNDERCARRIAGE AND FRAME

- Dozer with switch activated blade float
- Triple flanged track rollers
- Tie down anchor points



TB260 POWERFUL COMPACT EXCAVATOR



MAXIMUM ALL DAY COMFORT

The TB260 has been designed with the operator in mind. With a large comfortable cab, highback fully adjustable suspension seat, headrest and ergonomically positioned hand and foot controls, plenty of foot room, air-con and multi-vent heater.



The TB260 offers excellent all around visibility with LED workzone lights as standard and a gas lift-assist retractable front window, with removable / stowable lower glass. Extra cab features include a large skylight with sun-shade and a rain guard for open window operating.

A well-positioned colour visual display unit illuminates active operating switch functions; lift overload, ECO and altitude modes, auto idle and auxiliary detent. Operators can easily select auxiliary preset modes to match all types of attachments with optional password secure presets.



MAXIMUM SERVICEABILITY

The steel engine hood and off-side cover provide unparalleled access to engine and hydraulic components simplifying all aspects of machine maintenance - all accessible at ground level.

- Rear service door for access to the daily check points: dipstick, engine oil fill, engine oil filter and hydraulic pump pressure detection points.
- Clustered service points make for quick and easy regular service routines.
- Off-side lockable service panel for access to the hydraulic tank, control valve, fuel and air filters, battery, radiator, hydraulic and fuel cooler.
- Near-side fuel filler points with electric refuelling pump with fast fill-up and auto shut off as standard, stowed in a lockable compartment.



TB260 POWERFUL COMPACT EXCAVATOR

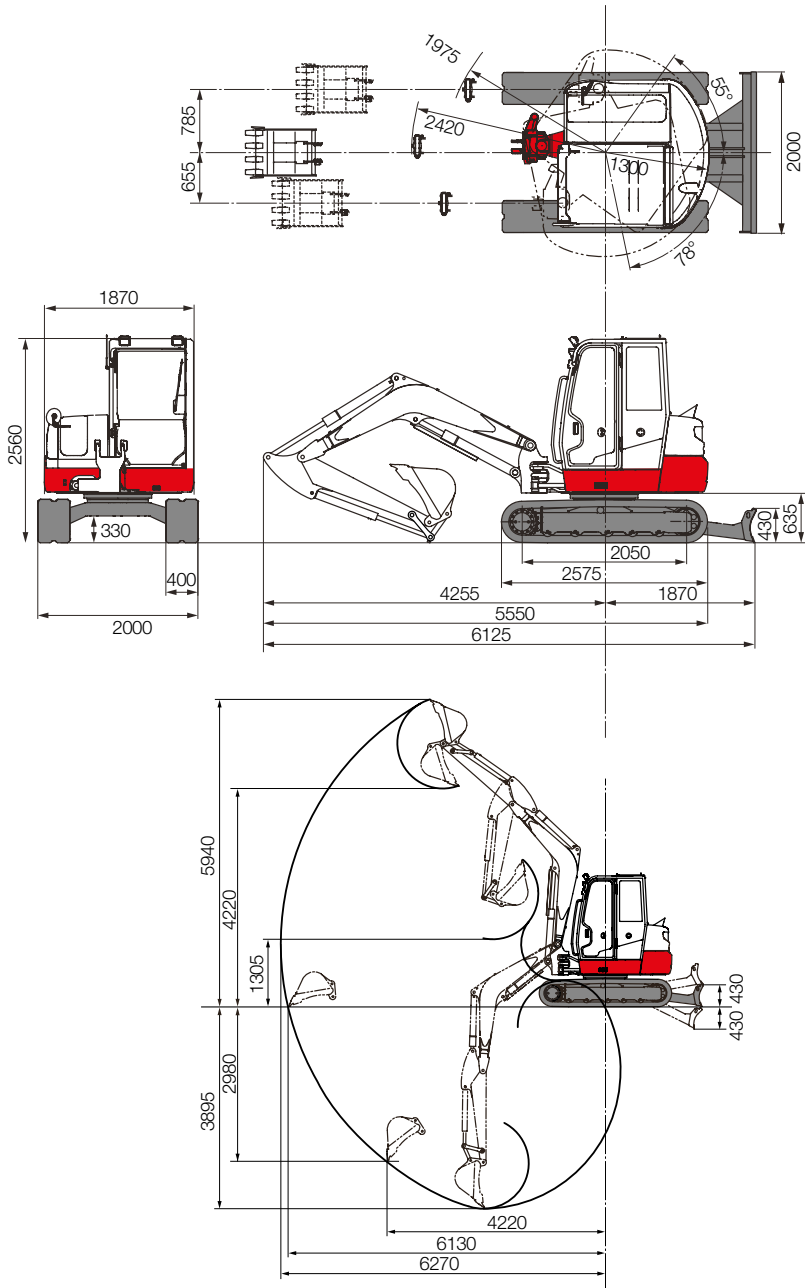

All dimensions unless otherwise stated are in millimetres.

TB260

Standard UK Specification - Long Arm / Rubber Tracks
Optional: Steel Tracks

Engine	
Make	Yanmar
Model	4TNV86CT-PTB
Rated Output (kW)/rpm	35.5 / 2400
Maximum Torque (Nm)	177
Cylinders	4
Displacement (cc)	2091
Electrical System	12volts 90amp

Dimensions & Weight	
Op. Weight (bucket, hitch, fuel) kg	5846
Length (Transporting) (mm)	5550
Width (mm)	2000
Height (mm)	2560
Ground Clearance (mm)	330
Min. Front Swing Radius (mm)	2420
Slew Radius (mm)	1300
Dozer Blade (W x H) (mm)	430 x 2000

Operating Information	
Max Digging Depth (mm)	3895
Max Dump Height (mm)	4220
Max Reach at Ground Level (mm)	6130
Max Vertical Digging Depth (mm)	3895
Max Bucket Digging Force (kN)	43.2
Max Arm Digging Force (kN)	25.6

Hydraulic System	
Set Pressure (bar)	240
Pump Type Rexroth	Var x 2 Gear x 2
1st Aux Max Flow l/min	102
Pressure bar	210
2nd Aux Max Flow l/min	44
Pressure bar	206

Swing System	
Boom Swing Angle (L/R)	78°/55°
Slew Speed (rpm)	9.4
Slew Motor Piston	Constant Volume Piston
Slew Brake	Wet Friction Plate

Undercarriage	
Traction Motor	Axial Piston
Traction Drive	Planetary
Traction Brake	Disc
Track Width (mm)	400
Ground Contact Length (mm)	2050
Ground Pressure (kPa)	31.5
Travel Speed (K/ph)	2.8-4.9
Maximum Gradeability	30°

Capacities	
Hydraulic System (l)	90
Fuel Tank (l)	81
Engine Lubrication (l)	7.4
Cooling System (l)	11

Health & Safety	
Noise / Sound Power Level (LwA)	97 dB
Vibration Hand Arm / Body m/sec ²	≤2.5 / ≤0.5

4/2024

**2 YEAR
2,000 HOUR**

WARRANTY

Takeuchi machines come with a 2 year/2000 hour warranty as standard.

Before fitment of a hydraulic attachment, machine auxiliary pressure and flow should be accurately measured. For all lifting specifications please refer to the lift charts on the Takeuchi website or operator manual.

In accordance with our established policy of constant improvement, we reserve the right to amend these specifications at any time without notice. Photographs shown may feature non-standard equipment.

For more information locally contact:



SCAN ME

To find your local dealer

Takeuchi Mfg (UK) Ltd, Unit E2B Kingsway Business Park,
John Boyd Dunlop Drive, Rochdale, Lancashire OL16 4NG
info@takeuchi-mfg.co.uk www.takeuchi-mfg.co.uk

@TakeuchiUK

TAKEUCHI
From World First to World Leader