

TB290-2
9-TONNE



**POWERFUL
COMPACT EXCAVATOR**

EXCAVATING EXCELLENCE

TAKEUCHI[®]
From World First to World Leader

TB290-2 powerful excavating and breakout force

The TB290-2 combines all the proven characteristics of Takeuchi excavators: smooth hydraulics, power performance, proven durability, high resale value, with maximum operator comfort and serviceability.

Takeuchi's TB290-2 is a proven powerful excavator ideal for major groundworks and earthmoving complete with Stage V compliant DPF engine for low emission zones. With a ground level reach of 7290mm, digging depth of 4580mm, dump height 5260mm and vertical dig depth 3820mm.

Accumulator assisted pilot controls combined with cushioned boom, arm and swing cylinders, help reduce shock and vibrations for a smoother machine operation.

The auxiliary detent switch prevents operator fatigue when using continuously operating attachments. Dual proportional control comes as standard.

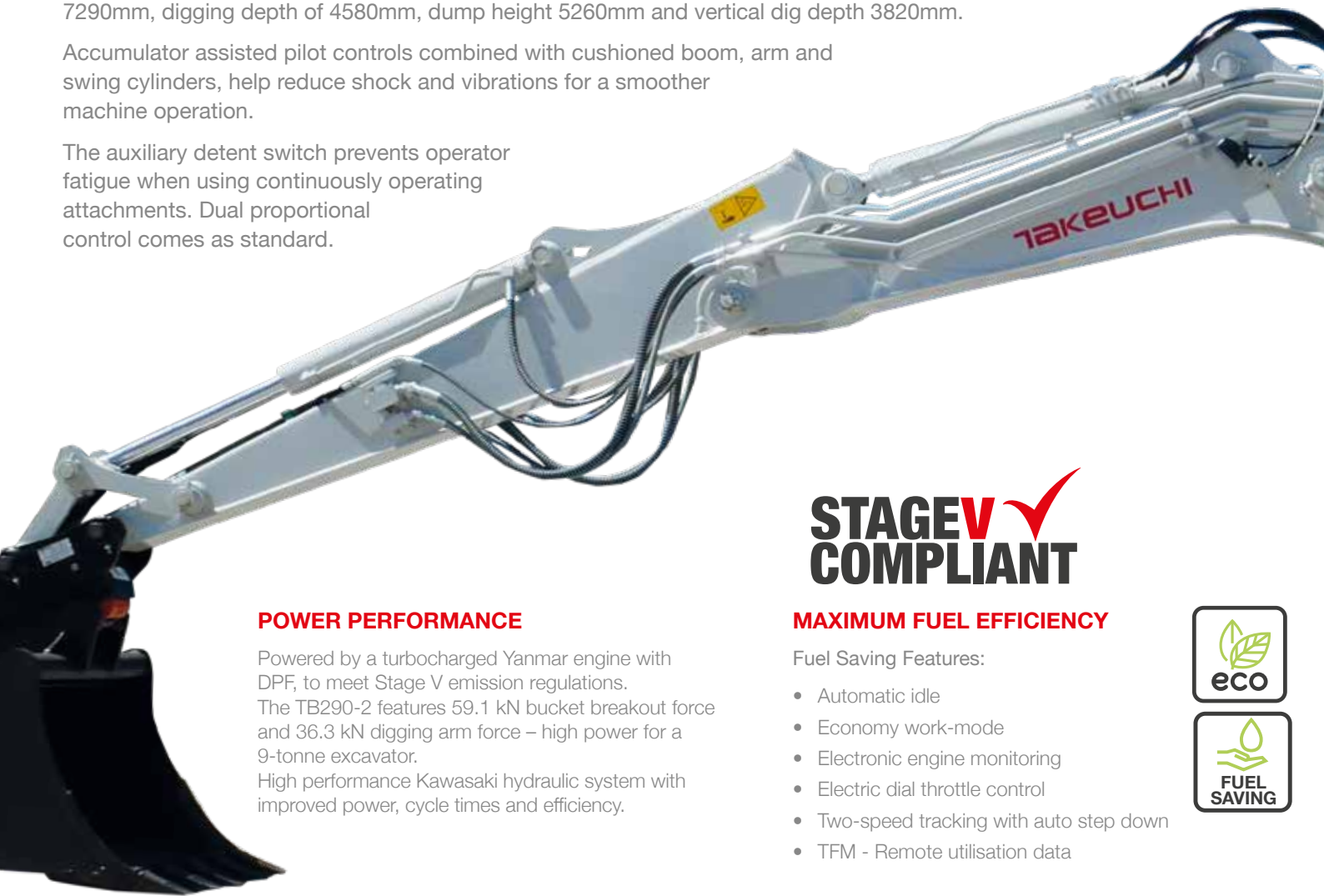

POWER PERFORMANCE

Powered by a turbocharged Yanmar engine with DPF, to meet Stage V emission regulations. The TB290-2 features 59.1 kN bucket breakout force and 36.3 kN digging arm force – high power for a 9-tonne excavator. High performance Kawasaki hydraulic system with improved power, cycle times and efficiency.

STAGE V COMPLIANT

MAXIMUM FUEL EFFICIENCY

Fuel Saving Features:

- Automatic idle
- Economy work-mode
- Electronic engine monitoring
- Electric dial throttle control
- Two-speed tracking with auto step down
- TFM - Remote utilisation data



ROBUST SITE PROTECTION

Cast steel wraparound counterweight with all-steel panels and four forward facing LED workzone lights on the roof and boom.

Hydraulic hoses well positioned to prevent damage from attachments.

Dual boom cylinders with hose burst check valves provide added lifting power and additional clearance for bucket and attachments.



TSS - TAKEUCHI SECURITY SYSTEM

The TB290-2 comes with **TSS** as standard. Includes 1 red master key and 3 black user keys. Can programme up to 13 user keys.



TFM - TAKEUCHI FLEET MANAGEMENT

TFM is a remote **TELEMATICS** system, using real time data to better manage your fleet and lower overall operating costs. Free of charge in warranty period.

ENHANCED FEATURES

A rear-view HD colour camera with auto-reverse activation for maximum visibility on busy sites.

Accumulator assisted pilot controls combined with cushioned boom, arm and swing cylinders, help reduce shock and vibrations for a smoother machine operation.

Boom and arm holding valves are factory fitted for added safety in the event of a hose burst failure. An audible warning lift alarm is standard for craning.

The TB290-2 comes factory fitted with steel hydraulic hitch pipework and with safe hand/foot activation switches.

Dual flow hydraulic lines operated by sliders on both levers, for smooth control of variable flow and detent to accommodate a wide range of attachments, with optional password secure presets.

The TB290-2 has matching pin and link dimensions to a Takeuchi TB370, so attachments are interchangeable.



COMPATIBLE BREAKER

The TB290-2 is compatible with a Takeuchi TKB402-S sound suppressed hydraulic breaker. Designed to meet the requirement for quieter operating environments.



RELIABLE TRACK DESIGN

The TB290-2 comes with auto track tensioning. Triple flanged rollers support the track in multiple positions improving machine stability. The upper roller maintains track alignment and helps shed debris.

High torque auto step-down travel motors deliver on-demand tracking power when dozing, turning and climbing.



STANDARD FEATURES

(see website for the complete features list)

OPERATOR STATION

- All steel Cab (ROPS/ OPG)
- Adjustable armrest and deluxe highback seat, retracting seat belt and drinks holder
- Cab mirror - 5 blindspot mirrors
- Wide-angle colour rear-view camera with auto-reverse activation
- Radio with stereo speakers MW/FM/ USB/ Bluetooth
- AC/ climate control/ heater/ de-mister
- Gas lift-assist window slides into recess
- Front screen rain guard
- Large fully supported foot travel pedals

ELECTRICAL

- Sockets 12V/USB in-cab & 12V cab-front
- Switched roof beacon power socket - 12V
- LED workzone lights, safety lights side/ rear
- Travel alarm
- Emergency engine shut-down switch
- Electric refuelling pump - extendable length

ENGINE

- DOC+DPF exhaust after treatment
- Dual fuel filtration - water trap
- Dual element air filter
- Service interval - 250 hours
- Working modes: Standard/ Eco/ Altitude



HYDRAULICS

- Cushioned boom, arm and swing cylinders
- Dual boom and single arm check valves
- Lift overload alarm
- Dual boom protection guards
- Aux flows - touchscreen adjustable
- Multi-attachment presets - password secure
- 1-way/2-way flow selector
- Aux with independent isolation valves
- Proportional auxiliary controls with detent
- Aux ports: 1st + 2nd standard, 3rd (pre-piped for hydraulic hitch), 4th optional

UNDERCARRIAGE AND FRAME

- Dozer with switch activated blade float
- Triple flanged track rollers
- Tie down anchor points
- Auto track tensioning system

SWITCH ACTIVATED BLADE FLOAT

To maximise ground finishing on-site the switch activated blade float is fitted as standard

A heavy-duty dozer blade with a cylinder protection guard.

Exposed ground level hydraulic hoses are spiral steel wrapped for added protection.



REDUCED TAIL SWING

The compact TB290-2 features a shorter than average tail swing compared to conventional 9-tonne excavators.

Just 1650mm tail swing radius with a 540mm overhang at 90° to track and rounded corners help minimise potential machine damage in restricted areas.



TB290-2 POWERFUL COMPACT EXCAVATOR



MAXIMUM ALL DAY COMFORT

The TB290-2 has a large cab with increased operator functionality and all around visibility with ROPS/OPG that gives the operator maximum safety.

The spacious styled interior ensures maximum operator comfort. With a fully adjustable deluxe high back, heated, air suspension seat for comfortable full-day working.

The cab has plenty of foot room and large travel pedals.

Maximum comfort comes with air-con climate control and a gas lift-assist retractable front window, with removable / stowable lower glass. The large skylight with sun-shade and a rain guard provide protection for open window operating.

Added cab features include a well-positioned colour VDU illuminating active operating switch functions; lift overload, eco and altitude, auto idle and auxiliary detent. Operators can easily select auxiliary preset modes to match all types of attachments with optional password secure presets.

A rear-view colour camera with split screen and auto-reverse activation for added site safety.

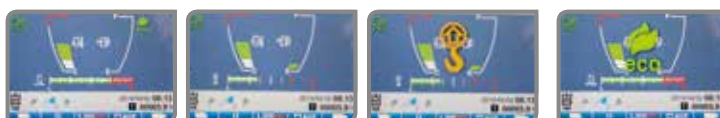

MAXIMUM SERVICEABILITY

The styled lockable engine hood and off-side cover provide unparalleled access to engine and hydraulic components simplifying all aspects of machine maintenance - all accessible at ground level.

- Well-positioned hydraulic fuel tank gauges and hydraulic control valve
- Electric refuelling pump with fast fill-up and auto shut off as standard.
- Side by side radiator, hydraulic oil cooler and fuel cooler are easily accessible
- The A/C Condenser swings out on a hinged frame giving easier cleaning access

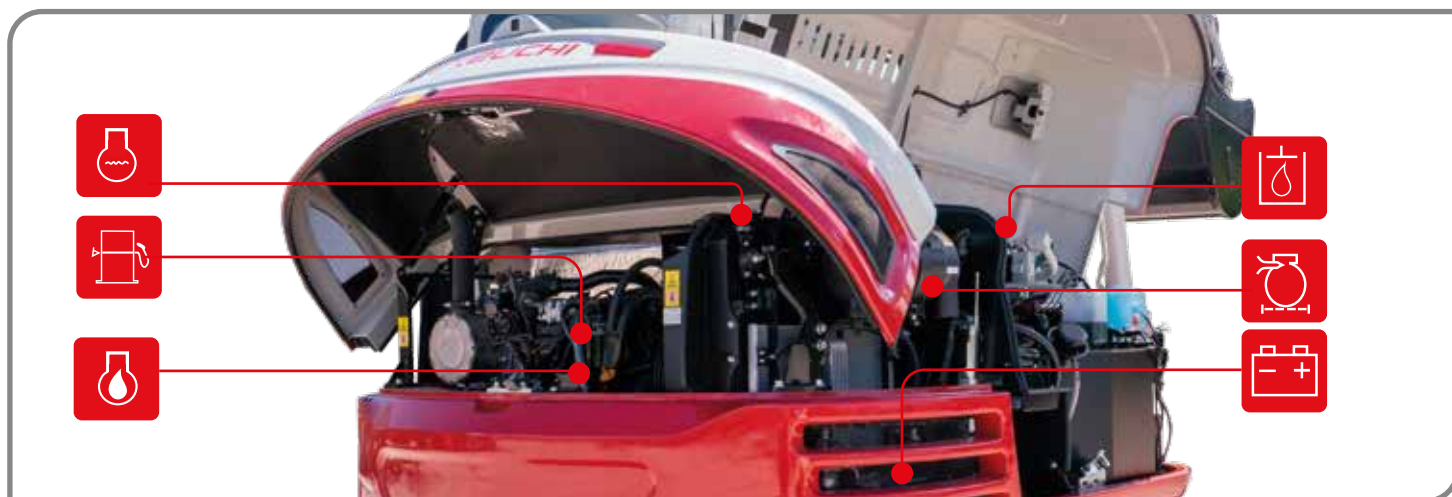

TB290-2 POWERFUL COMPACT EXCAVATOR

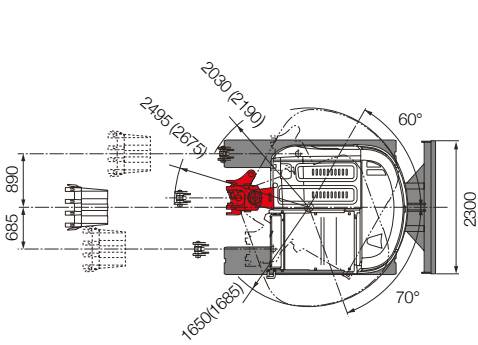

Mono Boom

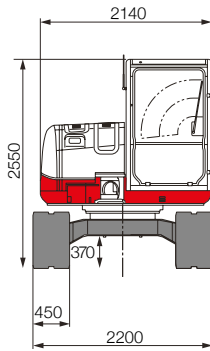

2-piece Boom

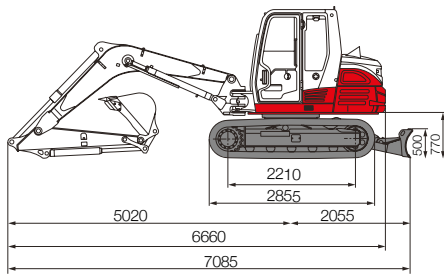

Mono Boom

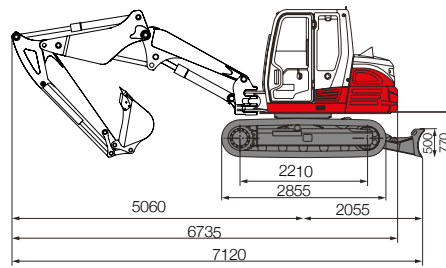

2-piece Boom

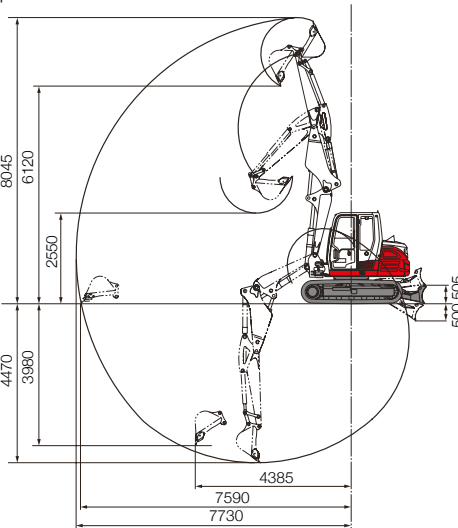
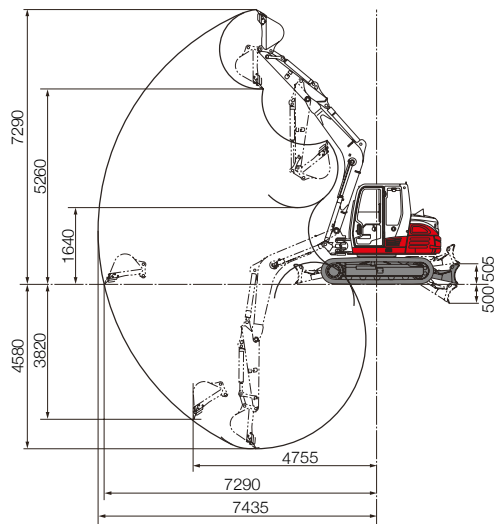

All dimensions unless otherwise stated are in millimetres.

TB290-2 Standard UK Spec – Long-Arm Mono Boom - Rubber Tracks Optional: Steel Tracks - (2-piece Boom)

Engine	
Make	Yanmar
Model	4TNV98CT-WTB DPF
Rated Output (kW/rpm)	51.6/2000
Maximum Torque (Nm)	308
Cylinders	4
Displacement (cc)	3318
Electrical System	12 Volt 90 A

Dimensions & Weight	
Op. Weight (bucket, hitch, fuel) kg	8572
2-piece	8715
Overall Length (mm)	6660 (6735)
Width incl. dozer (mm)	2300
Height (mm)	2550
Ground Clearance (mm)	370
Min. radius of machine & attach	2495 (2675)
Slew Radius (mm)	1650 (1685)
Dozer Blade (W x H) (mm)	2300 x 500

Operating Information	
Max Digging Depth (mm)	4580 (4470)
Max Dump Height (mm)	5260 (6120)
Max Reach at Ground Level (mm)	7290 (7590)
Max Vertical Digging Depth (mm)	3280 (3980)
Bucket Digging Force (kN)	59.1
Long Arm Digging Force (kN)	36.3

Hydraulic System	
Pump Type	Kawasaki Variable
1st Aux Max Flow (l/min)	100
Pressure (bar)	210
2nd Aux Max Flow (l/min)	60
Pressure (bar)	210

Swing System	
Boom Swing Angle (L/R)	70°/60°
Slew Speed (rpm)	10.3
Slew Motor	Axial Piston
Slew Brake	Disc

Undercarriage	
Traction Motor	Axial Piston
Traction Drive	Planetary
Traction Brake	Disc
Track Width (mm)	450
Ground Contact Length (mm)	2210
Ground Pressure (kPa)	37.6 (39)
Travel Speed km/h	2.6/5
Maximum Gradeability (degrees)	30

Capacities	
Hydraulic System (l)	140
Fuel Tank (l)	128
Engine Lubrication (l)	10.2
Cooling System (l)	14

Health & Safety	
Noise / Sound Power Level (LwA)	99 dB
Vibration Hand Arm / Body m/sec ²	≤2.5 / ≤0.5

**2 YEAR
2,000 HOUR**

WARRANTY

Takeuchi machines come with a 2 year/2000 hour warranty as standard.

Before fitment of a hydraulic attachment, machine auxiliary pressure and flow should be accurately measured. For all lifting specifications please refer to the lift charts on the Takeuchi website or operator manual.

In accordance with our established policy of constant improvement, we reserve the right to amend these specifications at any time without notice.

Photographs shown may feature non-standard equipment.

For more information locally contact:



SCAN ME

To find your local dealer

Takeuchi Mfg (UK) Ltd, Unit E2B Kingsway Business Park, John Boyd Dunlop Drive, Rochdale, Lancashire OL16 4NG
info@takeuchi-mfg.co.uk www.takeuchi-mfg.co.uk

@TakeuchiUK

TAKEUCHI
From World First to World Leader