

TB135

OPERATING RANGE

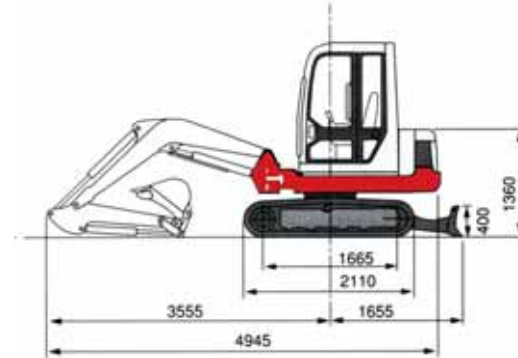

In accordance with our established policy of constant improvement, we reserve the right to amend these specifications at any time without notice. Photographs shown may feature non-standard equipment.

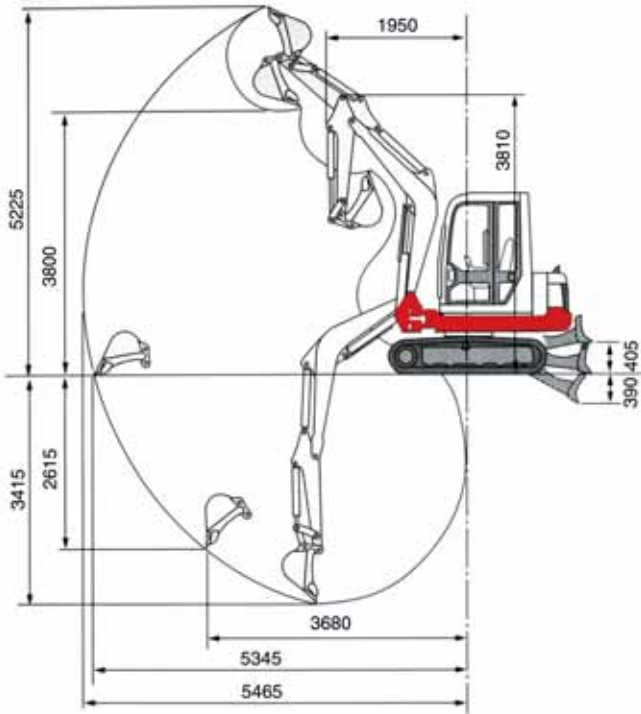
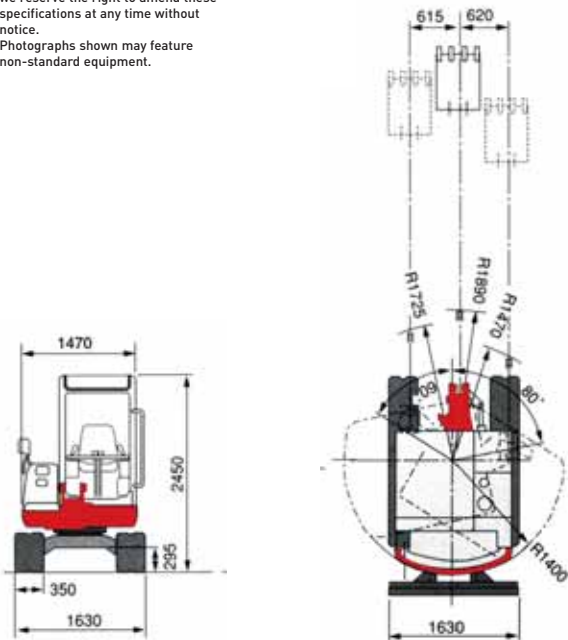

All Dimensions unless otherwise stated are in millimeters

DIMENSIONS & WEIGHT		OPERATING INFORMATION	
Operating Weight (kg)	3440	Max. Dig Depth	3415
Length (transport)	4945	Max. Dump Height	3800
Width	1630	Max. reach at ground level	5345
Height	2450	Max. Vertical Dig Depth	2615
Ground Clearance	295	Max. Bucket Dig Force (Kn)	26.5
Min front swing radius (80° boom swing)	1470	Max. Arm Dig Force (Kn)	18.0
Tail swing radius	1400	UNDERCARRIAGE	
Dozer Blade (wxh)	1630x400	Traction Motor	Axial Piston
ENGINE		Traction Drive	Planetary
Make/Model	Yanmar/3TNE88-TB	Traction Brake	Disc
Rated Output/RPM	20.7kW/2300	Track Width	350
Maximum Torque	106.9Nm	Ground Contact Length	1665
Cylinders/Displacement	3/1642cc	Ground Pressure (kpa)	27.1
Electrical System	12volt 40amp	Travel Speed (K/ph)	2.7/4.8
SWING SYSTEM		Maximum Gradeability	30°
Boom Swing angle (L/R)	80°/60°	HYDRAULIC SYSTEM	
Slew Speed (rpm)	9.2	Set Pressure (bar)	210
Slew Motor	Axial Piston	Pump Type	Variable(P1+P2)+Gear(P3)
Slew Brake	Disc	Hydraulic Flow (l/min)	37.3x2+21.9
		Auxiliary Flow (l/min)	59
		CAPACITIES (l)	
		Hydraulic system	85
		Fuel tank	52
		Engine Lubrication	4.8
		Cooling System	4.9

TAKEUCHI

Takeuchi Mfg (UK) Ltd, Lynroyle Way, Rochdale, Lancs OL11 3EX Tel: 01706 657722 Fax: 01706 657744

e-mail: sales@takeuchi-mfg.co.uk www.takeuchi-mfg.co.uk

Southern Office at Thatcham, Newbury Tel: 01635 877 196 Fax: 01635 877 195

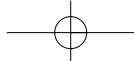

TB135

FULLY HYDRAULIC COMPACT EXCAVATOR



TAKEUCHI

TAKEUCHI

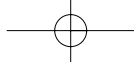
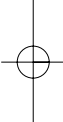
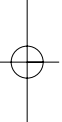

THE HIGH SPEED TB135 MINI

One of Takeuchi's 100 series range of mini-excavators the TB135 weighs in at 3440kg. and offers the operator unparalleled performance and comfort at this weight. The TB135 features two speed travel on rubber tracks and a fully fitted tilting cab, allowing superb access and routine maintenance - the cab also includes an AM/FM radio and heater.

Just look at the list of standard features and compare them to the competition - plus, legendary Japanese build quality means reliability second to none.

EASY ENGINE ACCESS AND MAINTENANCE



PECIFICATION EXCAVATOR



SUPERB OPERATOR COMFORT



STANDARD FEATURES

- Tilttable TOPS/FOPS cab
- Electrohydraulic push button control of auxiliary hydraulics
- Emergency engine shutdown/return-to-idle system
- Electronic engine monitoring system
- Cast iron, wrap around protective counterweight
- Steel engine cover
- Automatic fuel bleed system
- Variable displacement piston pumps
- One touch engine decelerator
- Safety lockout lever for travel and operating controls
- Remote slew lubrication system
- Two speed travel
- Two-way auxiliary hydraulics plumbed to dipper arm
- Double flanged track rollers
- Spring applied, hydraulically released disc type slew and parking brakes
- Precise response, proportional main control valves
- Simultaneous operation of cab swing and two digging functions with no reduction in speed
- Straight travel with simultaneous operation of digging and swing functions
- Cushioned main boom, arm and swing cylinders
- Hydraulic oil cooler
- Protective routing of bucket and arm cylinder hydraulic hoses
- Pilot operated joystick controls with armrest
- Main boom cylinder guard
- Low noise level and EPA exhaust emission compliant engine
- Engine oil 'Safedrain' system
- Fully adjustable suspension seat with retractable seat belt
- Vandalism protected lockable fuel tank and engine compartment
- Lockable operator's manual and storage compartments
- Boom mounted work lights
- Short pitch rubber tracks

OPTIONS

- 2 Year Warranty
- TKB201 Hydraulic Breaker
- Steel tracks
- Auger
- QuickHitch